

BIELLETE LIAISON
TAB EMPENNAGE HORIZONTAL

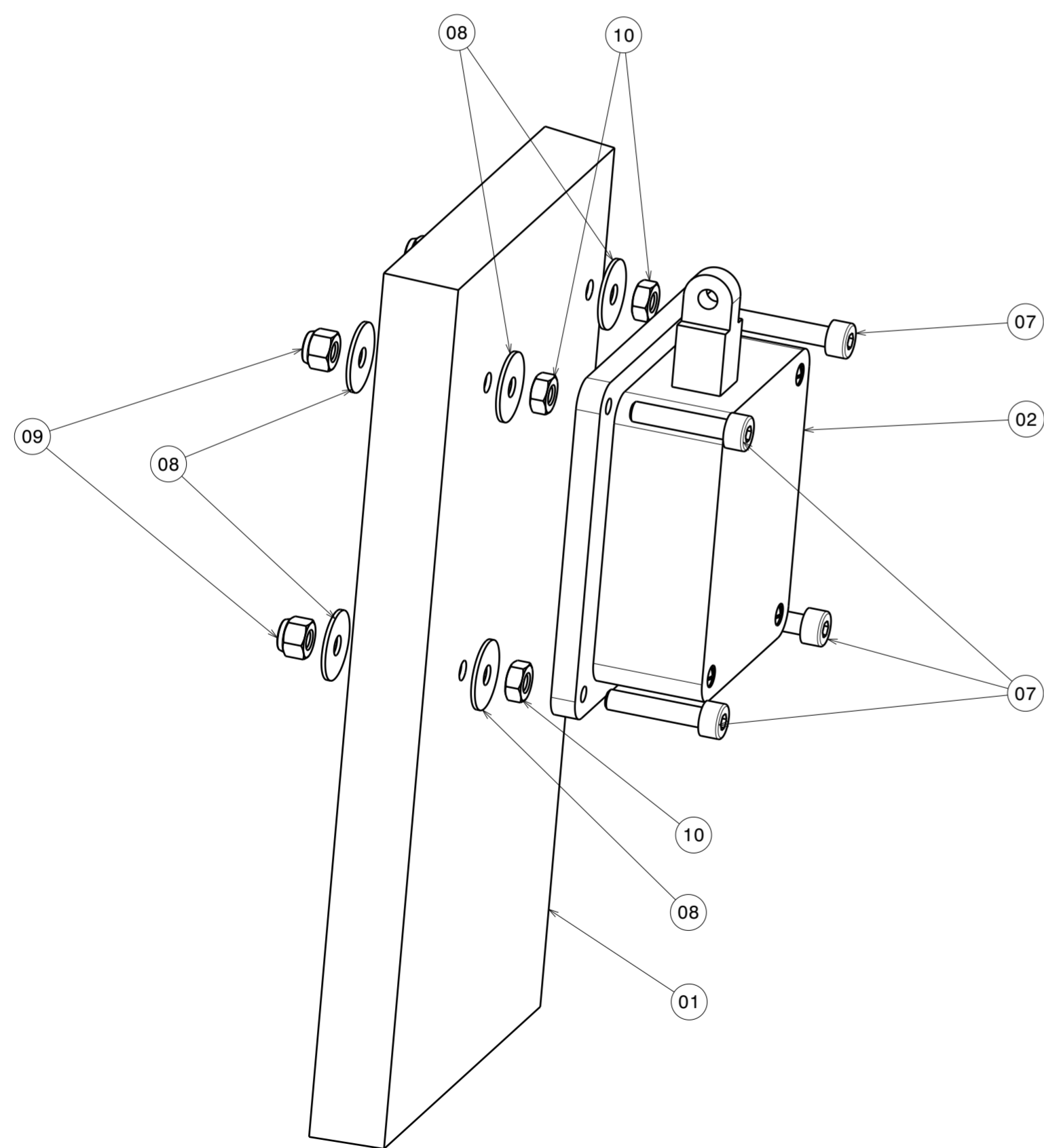

FIXATION SERVO TRIM PROFONDEUR

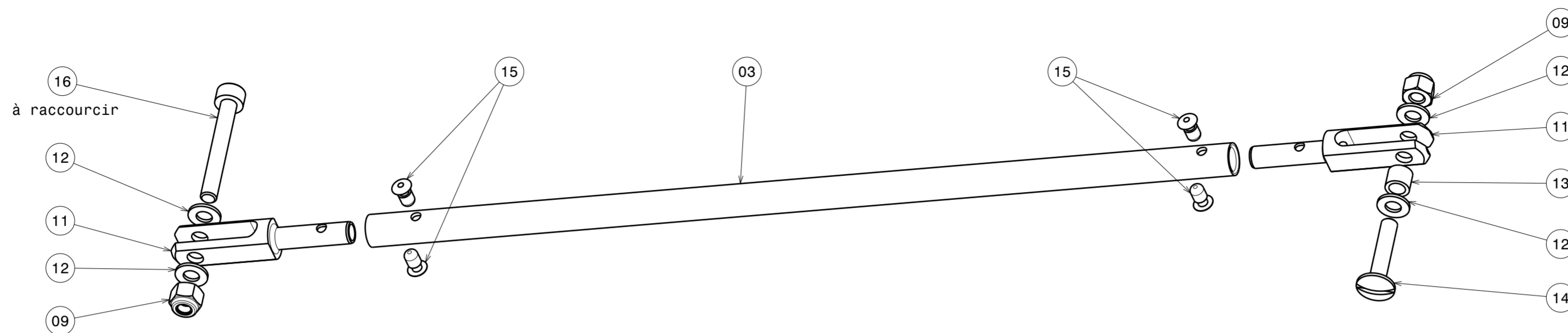
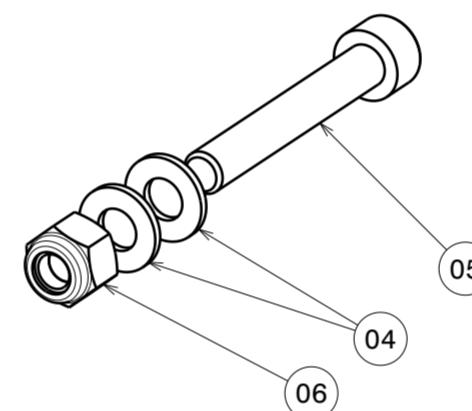

ENSEMBLE FIXATION
COMMANDE DE PROFONDEUR

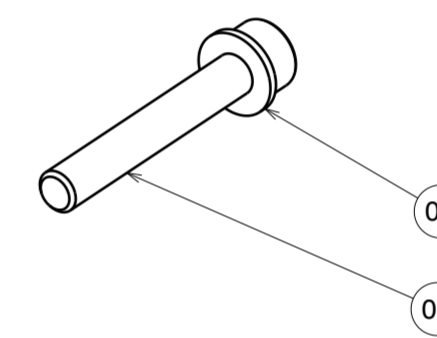

ENSEMBLE FIXATION
EMPENNAGE HORIZONTAL (x2)

(EMPENAGE NON REPRESENTE)

Repère	Ref	Désignation	Qte	Observation
16	ZMAVP2000	VIS CHC M4-30-20 CL 8.8 BZD	1	à recouper
15	ZMARI4100	RIVET POP ALU 2.4x6 TP	4	
14	ZMAVPE300	VIS POELIER M4-20 INOX	1	
13	MFUAL6003	CMD GAZ ENTRTOISE 4 x 6 L : 5	1	
12	ZMARO1000	RONDELLE 4x8x0.8 ZINC	4	
11	ZMAEQ900	EMBOUT CHAPE BIELLETTE TAB	2	
10	ZMAEP1400	ECROU H M4 CL.8 ZINC	4	
09	ZMAEP2000	ECROU FREIN NYLON HAUT M4 CL.8 ZINC	6	
08	ZMARO1200	RONDELLE 4x14x0.8 ZINC	8	
07	ZMAVP1800	VIS CHC M4-20-20 CL 8.8 BZD	4	
06	ZMAEP2200	ECROU FREIN NYLON HAUT M6 CL.8 ZINC	1	
05	ZMAVP5500	VIS CHC M6-40-24 CL 8.8 BZD	3	
04	ZMARO1600	RONDELLE 6x12x1.2 ZINC	4	
03	MEHCA4001	EH FIXATION BIELLETTE CARBONE	1	
02	ZMAEQF100	SERVO TRIM PROFONDEUR	1	
01	MFURE8102	EH FIXATION BOITE ATTACHE BIELLE	1	

ASMA-G8	27/11/2013	N MAHUET	07/01/2014	--	--
DESSINÉ PAR	DATE	VERIFIÉ PAR	DATE	APPROBATION PROD	DATE
DESIGNED BY		CHECKED BY			
MATIÈRE : Material	--			Matière ind.	--
Traitement : Treatment	--				
Etat de surface Surface roughness		Ebavurage / Edge deburring		PROJECTION	
Tolérances générales / Main tolerances		Marquage / Marking NEANT			
				MASSE CALCULÉE Weight calculated	ECHELLE Scale
				-- g	1:1
				FORMAT A2	FEUILLE Sheet
					1/1
					INDICE Issue
					--

 AUPA DYN'AERO 17 rue Saint Exupéry F-64230 SAUVAGNON +33 (0)5 59 33 18 74					
RPL4400					